



DOCUMENTATION TECHNIQUE

DERBI GPR50-R (DE 1997 À 2003)

MANUEL DU PROPRIÉTAIRE
(EN ANGLAIS)

WWW.50FACTORY.COM

INFO@50FACTORY.COM // 05 40 13 02 24

Manual del Propietario **GPR 50R**



NACIONAL MOTOR, S.A.

08107 Martorelles
(Barcelona Spain)
Tel.* (93) 570 20 10
Fax (93) 593 48 54
Télex 94 184 DERBI E.

DERBI POSTVENTA

Servicio de Atención al Cliente
Tel.* (93) 570 20 10 PostVenta



DERBI es 8 veces Campeona del Mundo de Velocidad, 7 veces Subcampeona del Mundo de Velocidad y 33 veces Campeona de España de velocidad.

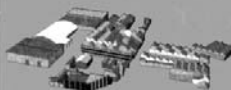

60.000 mts.² de Instalaciones Industriales para Fabricar Vehículos con la máxima calidad.



DERBI es **8** veces Campeona del Mundo de Velocidad. **7** veces Subcampeona del Mundo de Velocidad. **33** veces Campeona de España de velocidad. **7** veces Campeona Internacional de Francia de Velocidad. **2** veces Campeona Nacional de Francia de **Velocidad**. Cuatro veces Campeona de Suiza de Velocidad. Cuatro veces Campeona de Marruecos de velocidad. Cuatro veces campeona de Bélgica de Velocidad. Dos veces campeona de Francia **Sport**. Campeona de Europa de Montaña. Campeona de España **minimo consumo**. Campeona de España de Montaña. Campeona de Holanda de Velocidad. Campeona de Catalunya de **Montaña**. Campeona de Catalunya de Moto Cross. Campeona de Suecia de Velocidad. **Campeona** de Irlanda de Velocidad. Campeona de Guatemala de Velocidad. Campeona de Italia Junior de Velocidad. Campeona de Italia de Velocidad. Dos veces Vencedora Trofeo Nacional 75 c.c. Junior de **MotoCross**. Tres veces Vencedora Copa R.F.M.E. Junior de 75 c.c. de Moto Cross. Cinco veces Campeona de España de Moto cross. Vencedora Copa R.F.M.E. Junior de Velocidad **80** c.c.. Vencedora Copa R.F.M.E. Junior de Velocidad **125** c.c.. Vencedora Trofeo Nacional Senior de Velocidad 80 c.c.. Vencedora Copa R.F.M.E. Junior de **Enduro** 75 c.c.. Vencedora Trofeo Nacional Senior de Moto Cross 250 c.c. **Campeona** de España Juvenil-Junior de Moto Cross 80 c.c.

NACIONAL MOTOR, S.A. / DERBI desea agradecerle la confianza depositada por Ud. en la elección del modelo **GPR 50R**.

En este manual se especifican los principales detalles para el cuidado de su ciclomotor, para que obtenga el mejor funcionamiento y la mayor duración con un mínimo coste. Cuide su ciclomotor, La calidad DERBI se encargará del resto, con los recambios originales y una red Nacional de más de cuatro mil Agentes y talleres autorizados, estamos seguros de que obtendrá plena satisfacción en el uso del vehículo. Recuerde que **DERBI POSTVENTA** es un servicio creado para resolverle dudas y ayudarle a usted.

Bienvenido a DERBI

El logotipo DERBI es marca registrada y propiedad de Nacional Motor, S.A. Prohibida la reproducción total o parcial de cualquier fotografía, gráfico o texto insertado en este manual. © 1998 Nacional Motor, S.A. / DERBI

Impreso por Gráficas Morán, S.L. - Palamós (Girona) Depósito Legal: GI - 669 / 1997 - CODIGO MANUAL 0.0H.051.2.012.1

Thus atmosphere can You contribute to the conservation of medjo.

On his style to lead it also depends the fuel consumption and, therefore, the level of emission of polluting agents of his moped.

Also, the way to treat vehiculo influences in the level of noises and the wearing down of the same one.

In this Manual a series of information is included on an ecological conduction and to same economic time of their moped.

Sirvase to consider all marked texts of this Manual with uñ

Welcome You Proteja medlo atmosphere!

CICLOMOTORES DERBI

Our mopeds enjoys the sigulentes ventaldas:

WITHOUT MATRECUA WITHOUT CARD (SINGLE WITH LICENSE) USABLE
From 14 AN OS

thanks to that it fulfills the following characteristics in agreement with the present one Legislation:

1. Posee a motor of piston displacement nonsuperior to 50 c.c.
2. By its construction Km/h cannot develop in land a speed superior to 45.

In case of varying anyone of these characteristics, vehiculo is outside GARANTIA DERBI, since on a par it goes in damage of its good operation, DERBI shows its disagreement this behavior antirreglamentano, that goes in damage of all the users.

Datos personales:

Nombre.....

.....

Dirección

.....

Tel.

Compañía de seguros.....

.....

Póliza de seguros N.º

.....

Representante DERBI más cercano

Nombre.....

.....

Dirección

.....

Tel.

Jefe de Taller.....

.....

Tel.

.....

Dato del Ciclomotor:

Designación de modelo.....

.....

Número de chasis

.....

Número de motor

.....

INDEX

Way to orient itself in this book of instructions:

Adding is divided it in six capsulos as it indicates the adjacent table of matters. Capsulos sayings are located by means of the pictures of black color.

In the first pages of each capftulo is an introduction and index detailed of capftulo.

the titulos that head each page serve to locate to certain text, leafing through quickly the book.

In index of page 56 gina the figure pa in which is the information that needs.

INTRODUCTION PAGE

Identifications	6
Keys	7
Indications	7

CONTROLS INSTRUMENTS,

controls and switches	9 - 18
-----------------------	--------

EQUILPO AND ACCESORLOS

Qasolinal Tank coolant oil and reference	19 - 21
--	---------

STARTING, CONDUCCION AND RUNNING

Procedures, suggestions and Pa warnings	22 - 26
---	---------

MAINTANCE

Technica Asistencia and preventive measures	27 - 48
---	---------

POSSIBLE LOCATZACION AND REPAIRACION OF AVERFAS.

First aid - troubleshoot	49 - 50
--------------------------	---------

ESPECIFICACIONES

Table of technical specify-clones, index	51 - 56
--	---------

Due to his criter it of constañ improvement in their products, DERBI - NACIONAL MOTOR, S.A., reserves the right to introduce the modifications that create oportune, without previous warning.

IDENTIFICACIONES

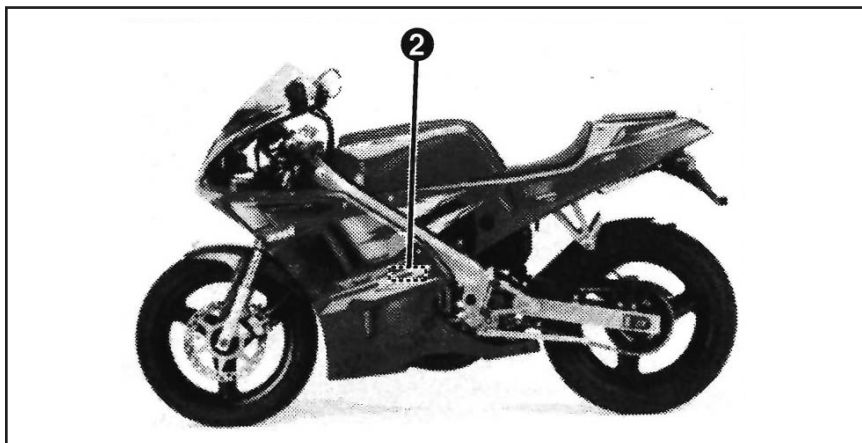

Location of the number of motor.

the number of motor is recorded in the leaves superior from left Body (2)

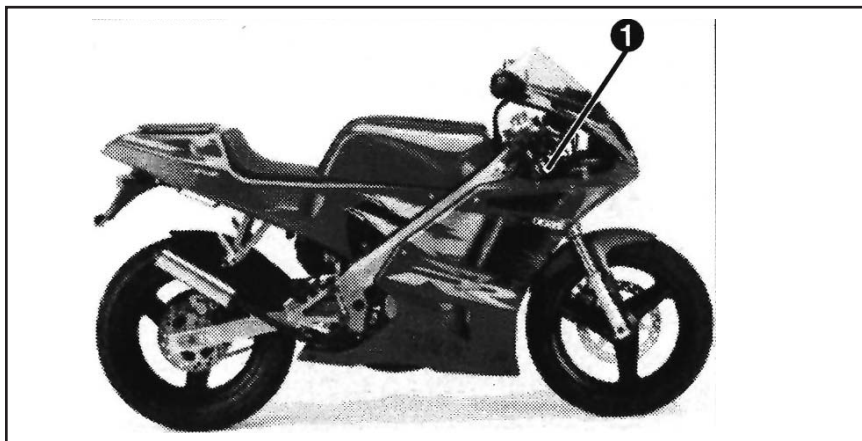

Location of the number of the frame

the number of the frame is recorded in the accept right of the tube of frame (1)

LIAVES AND INDICATIONS

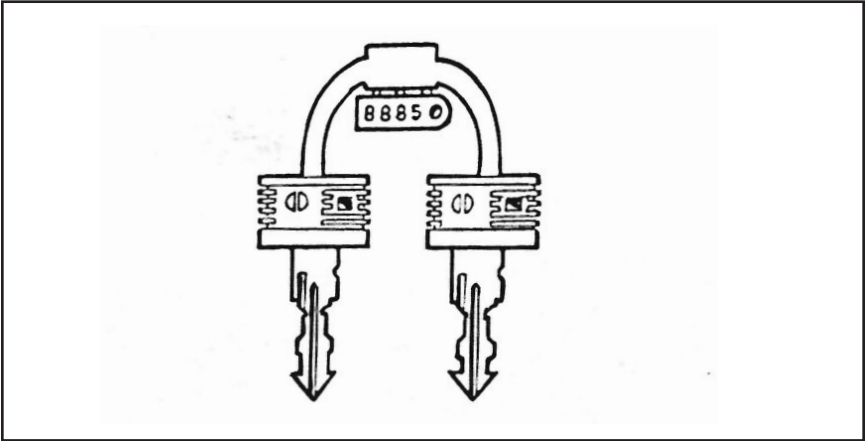

Keys

With moped the two are given haves that is used indifferently for the lock as contact covers tank gasoline and access tank of expansion and oil.

ATTENTION

For llamar the attention of the reader on important points indications are used sigujen-tes: "observation", "uyllavisoll precaution...

OBSERVATION:

The observations give corn-plementarios advice explain the text.

PRECAUCION!

With this heading one notices that the maneuvers at issue can cause deteriorations in vehfculo wears away premature.

AVISOL

The warnings notice that the maneuvers is dangerous and that podrfa to cause injuries

INSTRUMENTS AND CONTROLS

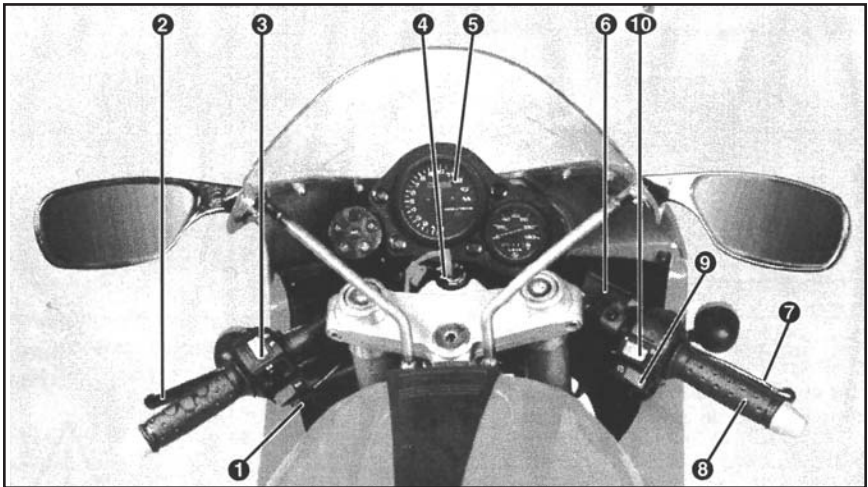

1. - Control to starter (choak)
2. - Control Engages (clutch)
3. - Commutator intermittent lights (signal) and horn
4. - Ignition Lock
5. - Tablier (tachometer)
6. - the tank liquido front brake
7. - Control front brake
8. - Throttle
9. - Electric starter
10. - Head lights

INSTRUMENTOS - CONTROLS AND SWITCHES

Panommica to tablier and controls

This CAP ftulo contains one descripci3n detailed of all the instruments and controls of special interest for the usuado one.

Index of capftulo	Pages
Tablier	10
Switch lights and starter button	11
Commutator lights, intermittent and pulser	12
horn Control	13
front brake	13
Ignition key lock	14
Order engages of the slutch	15
Choak	15
Control back brake	16
Handle of shift gear	17
gasoline Faucet switches	18

TABLIER

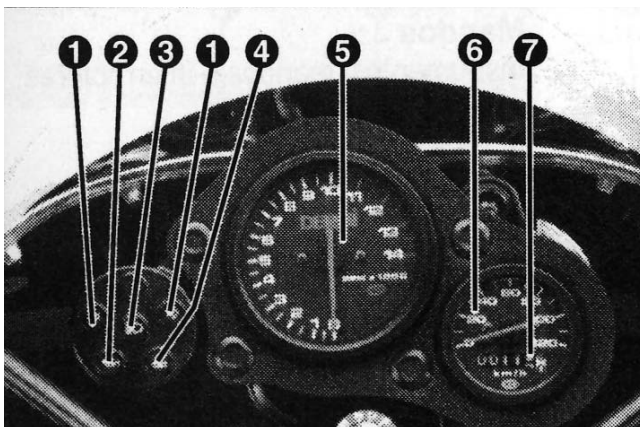

- (1) Indicator signal
- (2) Indicating oil reserve
- (3) high beam Indicator
- (4) Temperature indicator
- (5) Revolution counters (Tachometer)
- (6) Speedometer
- (7) Odometer

SWITCH LIGHTS AND START BUTTON

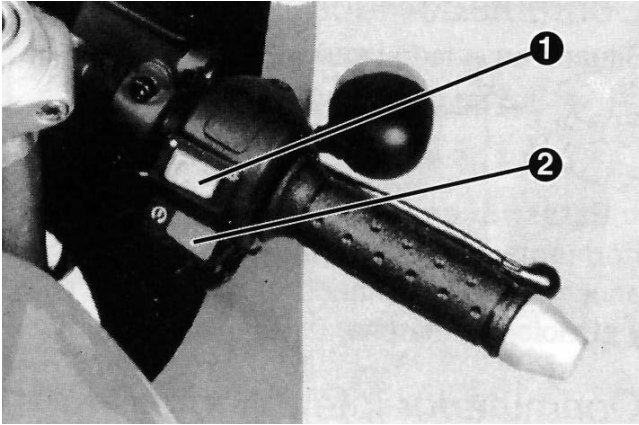

Interrupto luces

Located in the right side on dull left, lights off (1)

● right, no lights



Motor in march, lights on



Pulser starts

Pulser starts in the right side of the handlebars (2). To press it in continued form until the motor starts up. To see the instructions of beginning in section of starting and conduction, pages 23.

COMMUTATOR LIGHTS, INTERMITTENT & PULSER

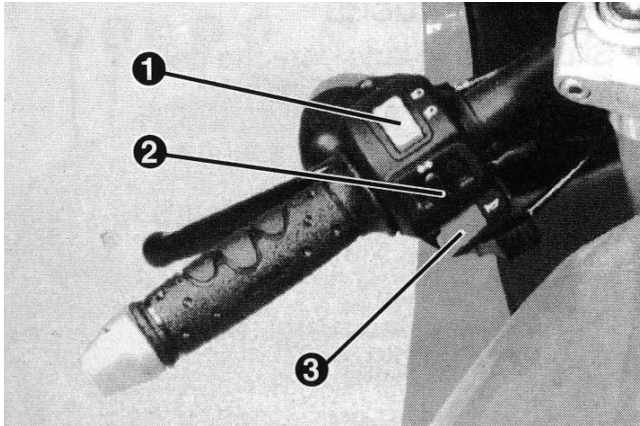

horn

the horn is located in the E left side of the handlebars (3)

Commutator lights

Located in the left side of handlebars (1)



high beam



low beam

These lights do not ignite If before engine starts it has not been put of in cendido On guard the control of the switch lights and the motor in runs.

Commutator intermittent - signal lights

Located in the left side of the handlebars (2)

Center - Intermittent extinguished off

Right - Intermittent the aright ignited

Left - Intermittent left side ignited

the control intermittent after being driven to right or left the, car In order to extinguish the intermittent ones, push the control downwards and maticamente returns to its starting point.

CONTROL FRONT BRAKE AND GAS

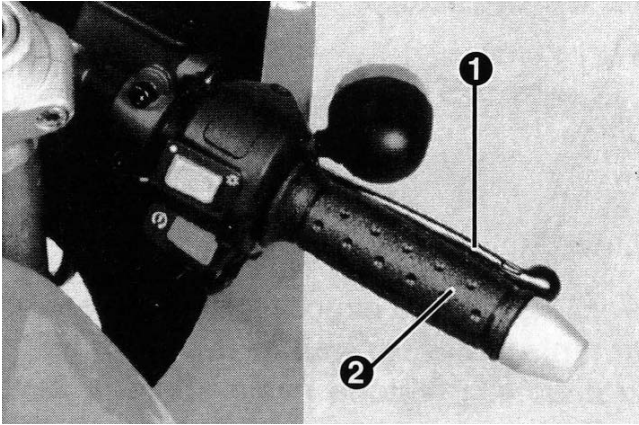

Control front brake

Located in the accept right of the handlebars (1). To put special attention in the always trying to avoid the blockade of the rolls.

Control the gas -

Located in the right side of handlebars (2). With the rotation inwards of the empunadura the is obtained opening of the trottle of the carburetor.

IGNITION KEY

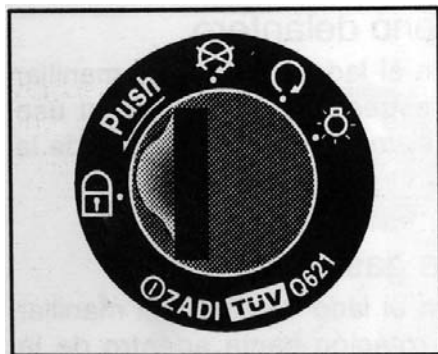

Lock of contact

Position of the have



- Motor unemployed and with blocking.



- Position takes motor.



- Ignited Lights (motor in march)



- to block the direction, completely turns the handlebars towards right the left. Press the llave downwards leaving returns to its place, and despu~s g(rela until the position ~ and extra igala.

CONTROL OF CLUTCH AND CHOAK

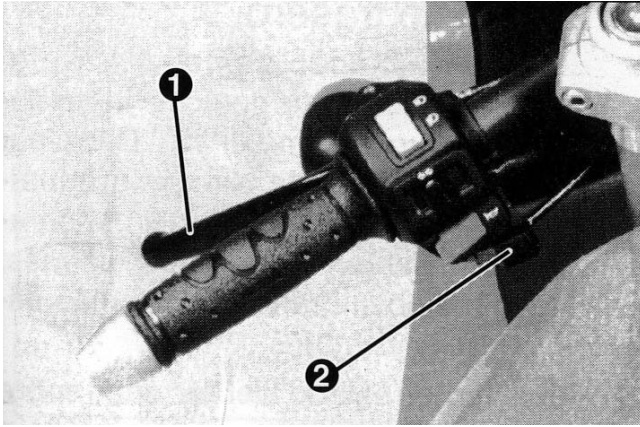

Control of clutch

and the maneta of the clutch control is located in the accept left of mani-rolling (1). Tightening thorough maneta happiness against the handlebars, el becomes disconnected engages the clutch, releasing to engage the transmission of the motor.

Leaving the smoothly maneta the clutch Is connected uniting the motor to the transmission, that with a march engraba-it gives transmits through camblo, the forces of the motor to the rolls back.

Choak

Located in the left side of the handlebars (2). This control solo has the purpose of facilitating the engine start-up. To use only when the motor is cold.

CONTROL BACK BRAKE

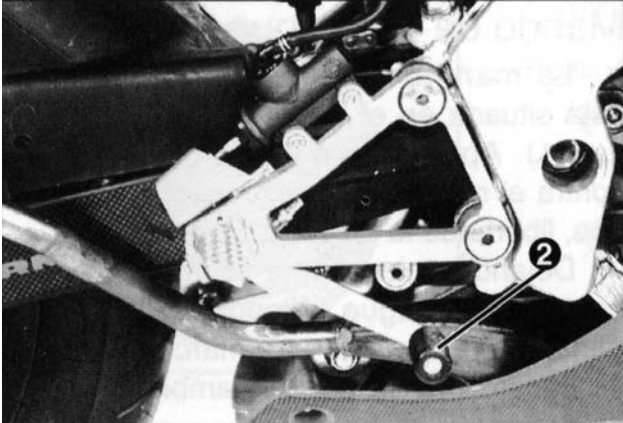

Control back brake

the pedal of control of the back brake, is located in the leaves from the cycle, ~ right motor, to the height of the motor (2). Mind must be ~ driven with the end of the gradual foot. To combine the use of the sero brake tra- with the forward brake necessities, of this form obtendran brakings more effectiveness.

ATENCION

to the state of the land! mainly If this it is asphalted and it wet gravil the exists.

GEARSHIFT

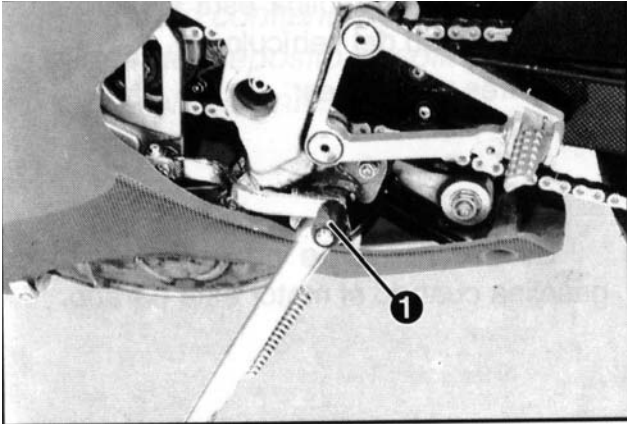

the gearshift is located in left side of the motor (1) It is driven with the foot and it must be accomplish with decision towards engage of the clutch. After to have carried out the change of gears, return the foot of the pedal, which will retake to its primitive position automatic Starting off of the deadlock, the the marches introduces of the following ' way:

- Pushing the handle downwards the 1 to gear is introduced.
- Pushing the handle upwards, 2, 3, 4, 5 and 6.~ are introduced the gears. In order to reduce, to drive the downwards handle.

IMPORTANT:

Handle of camblo the gearshift must drive always after to have unclutched and to reduce to minimo the control of the gas.

THE GASOLINE FAUCET

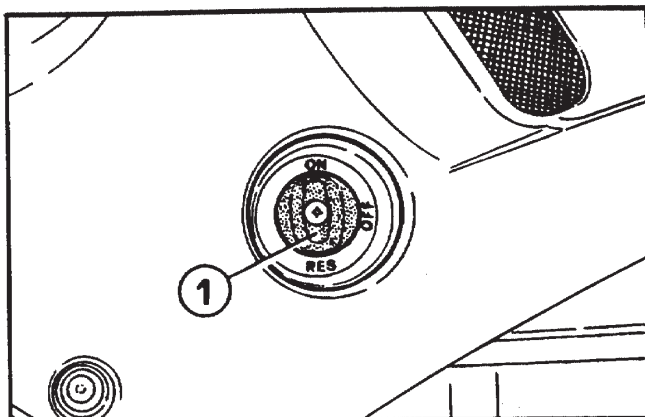

is located in the left side of vehiculo (1).

It has three positions:

ON - Abierto

OFF - Closed

RES - Reserve

He is advisable to close the gasoline faucet when the motor is stopped.

EQUIPMENT AND DEPO ACCESSORIES

silo gasoline, oil and coolant

GO Equipment and accessories This CAP ftulo contains one descripcidn detailed of the depdsito gasoilna, cooling lfquido oil and.

Index of capftulo	Pages
Gas tank	20
Oil tank	21
Tank cooling	21

THE TANK OF GASOLINE

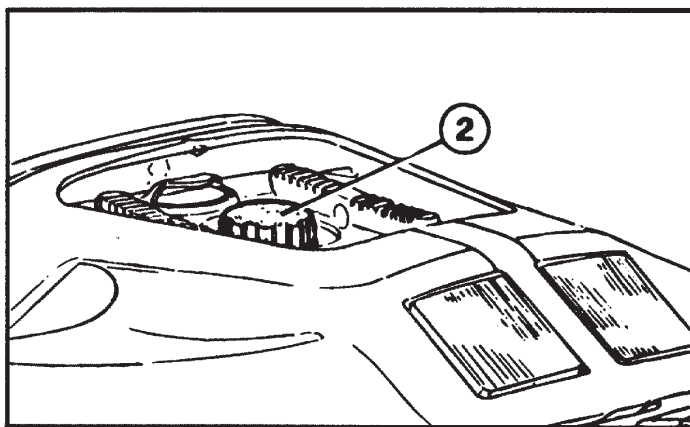
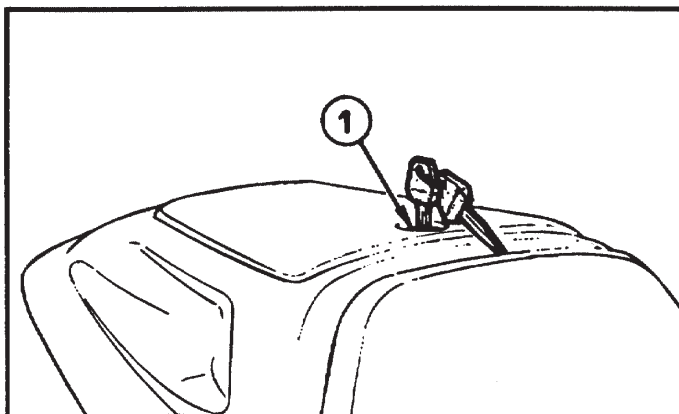

Gas tank to accede to the cork of the gas tank (2) is necessary to unblock the cerra- lasts (1) placed behind sill in of the pound - to. the gas tank has a layer store of **7.250 liters** and one reserve of **1.700 liters**.

When refuelling, is advisable that car- burante does not go beyond limits inferior of the load mouth, making sure siem- pre that once finished to the operation, the cork is well spiral. **Na of 98-100 uses gasoli- 2 SUPER octanes.**

THE TANK OF OIL AND THE TANK OF COOLING

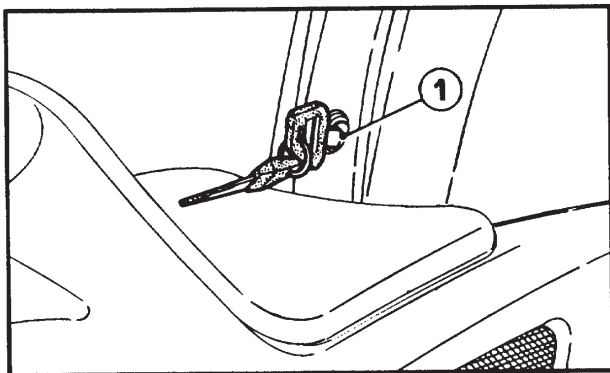

Tank the of cooling oil tank

The to access to the oil tank (4) and the tank of the eliminate coolant (3) is to unblock the placed lock (1) in front of the saddle of the pilot and to raise the storage cover .The oil tank has - a capacity of **0.730 liters** and one to reserve **0,180. liters**. To use sinjetico oil **600 2T**

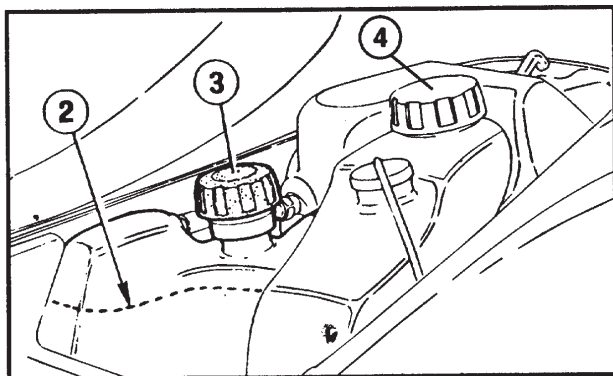

Tank the eliminate coolant

Each 1500 km after lengths x 3/trips, is due to control with the motor in cold, check the level of the eliminate of refrigeration.

Compruebe that the level (2) of refrigerante is more less in the half of the expansion tank. In case low, completes the fill. Capaci you give of the circuit of refrigeration is of **0.950 liters**

STARTING, CONDUCTION AND RUNNING

This cap(tulo deals with the system the starting, praticos aspects of conduction and running.

Starting, conduction and running

Procedures suggestions and

Index warnings of capftulo	Page
Engine start-up	23
Instructions for a correct conduction running	24
Instructions for the break-in	25
Advice who extend the life of their moped	26

ENGINE START-UP

Instructions for the beginning of the motor

- To introduce the handle of ignition in the ignition and to turn it to run position
- To open faucet of the gas tank.
- If the motor is cold, to tighten the choke.
- To push the start button to maintain it pressed until the motor starts up to the first attempt.
- Later on to have started the engine, let tighten the choke. When the motor is hot, it is necessary to start without the choke.

PRECAUTION

- Do not press the starting button when the motor is in march since it could damage the starter engine.
- the motor does not have to work with the battery disconnected voltage regulator, it could damage the electric installation.

It does not have to start the motor in march with no need. Don't idle starting immediately.

AVISO!

It is very important to verify before putting the motor in march, that the gear is in the position of neutral.

CONDUCTION

Instructions for a correct conduction.

- the technique of the good to lead, is the art that allows to remove maximum yield from the vehicle without forcing its mechanics. Our experience allows us to advise us:

Precaution!

- to introduce the speeds, to drive with the foot the handle of the camblo siluado to the left of the motor, the time that presses the clutch (left) and a little gas is cut.
- first it enters and the others downwards upwards.
- These movements must become with rapidity but without precipitation, to avoid that the motor always undergoes during the accomplishment of these maneuvers and driving the clutch.
- This change, again designed, needs little pressure of the foot so that the gears enter. It is recommended not to drive the handle with excessive force as it only harms the mechanisms.
- In order to circulate around slopes, it considers that not to maintain long time a same gear, the yield of its moped is the optimal one. When it notices that in spite of giving more gas, the speed diminishes, changes to the gear immediately inferior; it will notice that the moped returns to resume and increases his speed.
- This camblo must be made quickly, in order that the vehicle does not lose excessive speed to lower to a slope dead o'clock, to do fails to take advantage of its braking effect of the motor. It must lower with the same gear that had to use if pending the raised. the contrary goes against 10 arranged in the Highway Code.
- When it makes prolonged reductions remember once in a while to give to gas in order to lubricate the motor.

BREAK-IN

Instructions for the running

OBSERVATION: -

-the duration and yield of their moped depend in much on the treatment that receives during the period of running. During this period, the movable pieces that form the totality of their mechanisms, are smoothed, adapting an a others until their perfect connection.

- it will not carry out a better running to circulate very slowly, but leading with taken care of smoothness.

During this perfodo, he is recommendable to lead to 3/4 of gas of the accelerator, trying in cases in that it is precise to march thorough gas (advancements, pronounced hills, etc.), that the operating time to top, is 10 shorter possible.

- the 1000 Routes first Kms. must change the oil of Body. To use oil **TRANSOIL 10W 30**, amount **0.650 liters**. Also to the first 1000kms. it will have to come to a revision of completion the in any agency DERBI. is very important

ADVICE OF EXTEND THE LIFE

Advice who prolonged the - life of their moped.

- it does not maintain gas to top during long time.
- Always take the motor in that point (3/4 of gas) in which always it can give something more and It will save gasoline
- To the gas will extend to the life of the motor to restrain closing.
- Restrain with smoothness, watching the land that is above. In dry asphalt it initiates the restrained with the front brake and ends both. In wet land, with sand and gravilla, never uses the front brake and takes longer distance to stop the moped.
- In the curves it does not incline in excess, it dejesse llevar by his DERBI, it maintains the layout and maquina the indicated its position to him.
- When starting, it gives smooth gas gradually and loosen the clutch progressively.
- Stop the motor in the propitious occasions of the deal.

MAINTENANCE

the Technical attendance and preventive measures

Maintenance Index of capftulo	page
Injection oil Lubrication	28
Filtro air	29 - 31
Carburetor	32
Spark plug	33-34
Lubrication and lubricates	35
Admission by láminas	36
Regulations	36
Tension chain	37
Characterfsticas of the disk brake	38
Maintenance brakes	39
Nose light	40
Lamps Light	41
Pressure of the tires	42
Control the eliminate coolant	43
Battery	44 - 45
Fuse	45
Picture of maintenance and lubricates	46
Cleaning	47
Conservation in long periods of inactivity (storage)	48

This cap/tub deals with the system maintenance and controls of routine that can take place to have the security of which the moped est~ in perfect mecanicas conditions.

INJECTION OIL

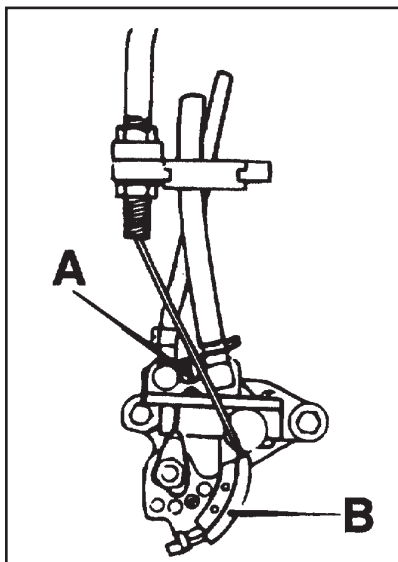

injection Oil lubrication

This model has a system of injection oil lubrication, formed by the tank of the oil, located next to the tank of the cooling líquido and the booster pump, located in the covers of yje right Body.

the tank, with capacity of **0.730 liters** has a reserve indicator that ignites the reserve informer oil located on the board, when the less lubricant to about **0.180 liters**

Possibly purge of the air of the can be come to the oil pump.

This operation is necessary whenever the dismounts the pump, becomes disconnected the tube of feeding of oil when the tank of the lubricant has completely remained emptiness.

In such case of coming to the sigulentes operations:

- To drain the gas tank and clean it with 2 or 3 liters of mixture all % of sintetico oil type 600 2T.
- To start the engine and to rotate it to the slow motion.
- To relax the screw of purge (A) and at the same time to rotate with the the hand control lever (B) of the oil pump until it leaves a flow continuous oil and without bubbles.
- Next to tighten the purge screw (A).

Note: For greater security, it is advised to use the mixes putting in the tank and only later to fill up with super gasoline.

AIR CLEANER

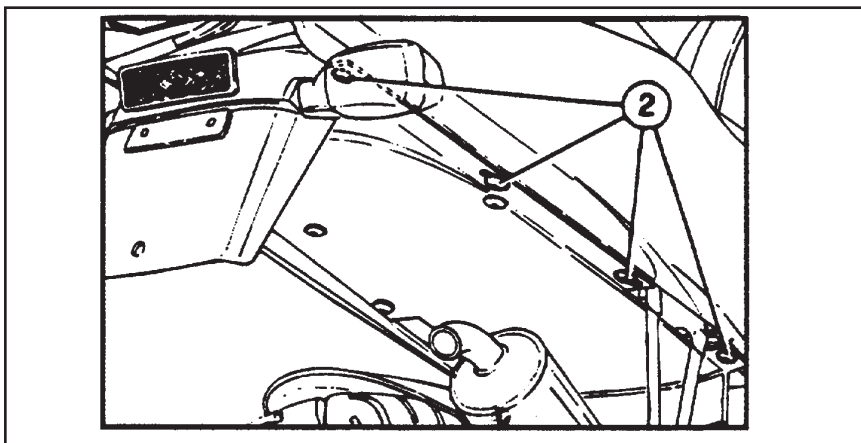
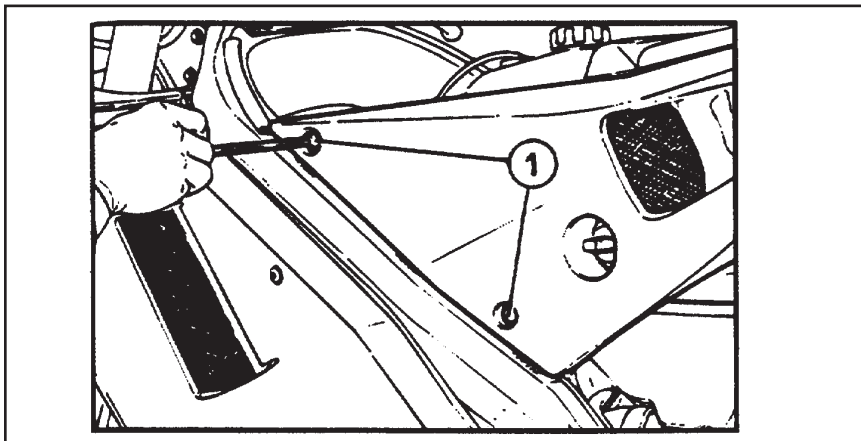

Cleaning air cleaner

If the foams has obstmido with dust, will au-lmentará the resistance of admission with a lost resultant of power output and an increase in the fuel consumption. It is recommended to clean the skims each 2,000 km in - agreement to the sigulente procedure:

- Clearing the four screws (1) and the eight screws (2) that fix the carroceria back.
- It disconnects of the main wiring the connections of the tail navigation light and the indicators of
- disassemble the body with light.

AIR CLEANER

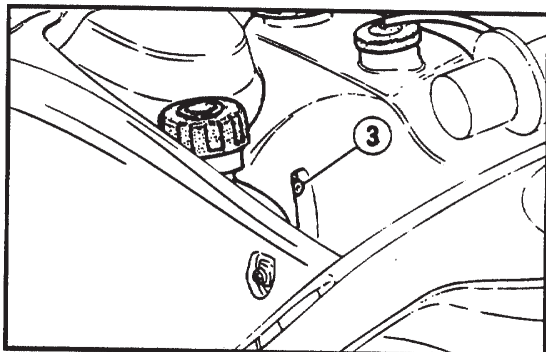

- Clearing the front screw (3) that fixes the deposits oil, coolant in the tank of the fuel.

- the Relaxes clip (4) that fixes the sleeve to the carburetor.

- the Extracts box of filter (5) of the connections in the frame.

- Clearing the four screws (6) that fix the covers.

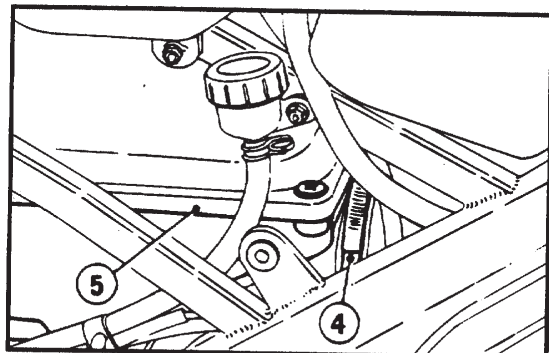

- Extracts the air cleaner (7).

- a container Fills with the eliminate nonflammable cleaner. Submerge the skims several ls

- It expels the eliminate cleaner pressing goes times until it is totally clean. rias times the filter with the palms of hands. It does not double squeezes the filter, since it will bcasionará fissures in.

- oil plenty Submerges the skims filter in a container " FILTER OIL "and despuos with the palms of the hands to press repeated mind until expelling the oil.

AIR CLEANER OR

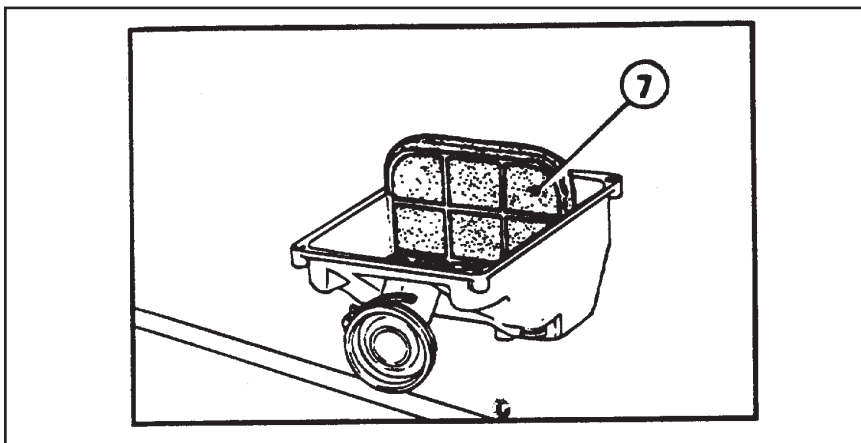
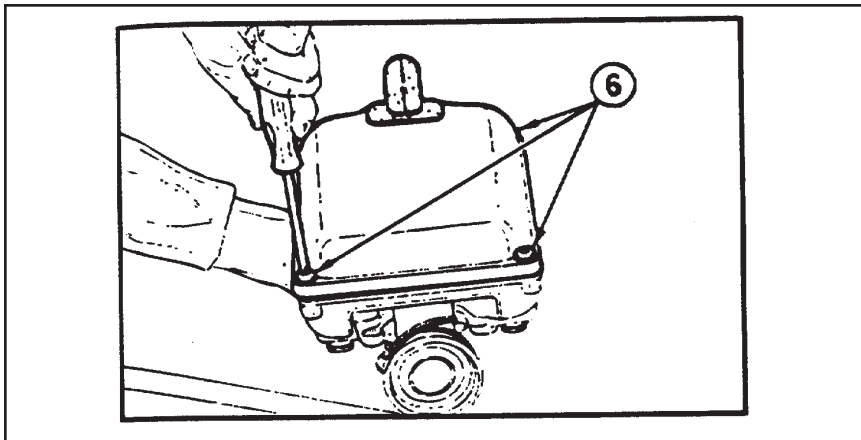

- Once it has the foams clean, montela If Iguiendo the inverted order of disassembling.

Precaucioni

- Before and during the cleaning the examines meticulously skims filter air, If it sees that he is deficient, must replace it p&r one new.

- If it leads by dusty highways, it must clean the skims filter more frequently air. Asegurese whenever the foams is in excellent conditions. the life of the motor depends mainly on this component.

IT NEVER MAKES WORK the MOTOR WITHOUT FOAM FILTER AIR.

CARBURETOR

Carburetor

A carburetion without problems is with a good engine efficiency. the carburetor has been fit in fábrica to offer the better carburetion. It does not try to alter this adjustment.

OBSERVATION:

Peribdicamente is advisable to make a cleaning of the carburetor, using gasoline lmpia and air to pressure of ideling

Regulation of ideling

Regulation sta operation must be made with the hot motor, deadlock and without giving gas, ralent turns the thyme regulation inwards or outwards until the slow motion of the llege motor to a point in which the motor almost is stopped, ' but that goes round. For any other regulation of the carburetor we advised goes to him to an Official Servicio DERBI.

PRECAUCION

the adjustment of the slow motion of the motor, is gale always with the hot motor.

SPARK PLUG

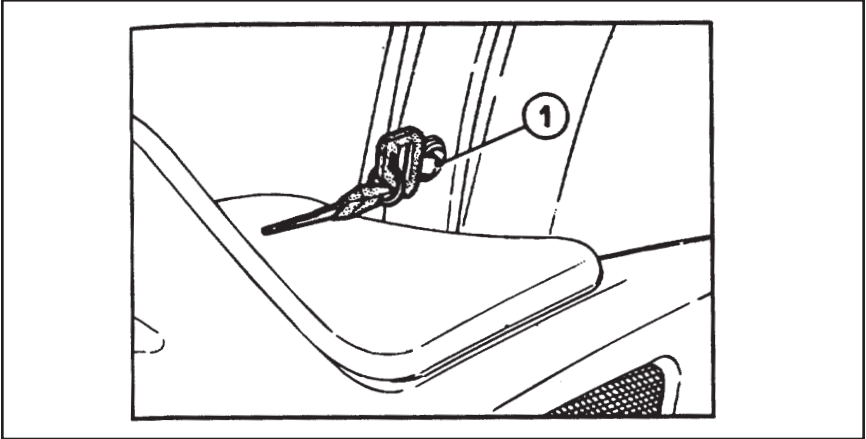

- to accessed to spark plugs of the pilot is necessary to unblock the lock (1) placed ldel ahead and to raise the covers of the compartimientto portacasco.

- Clearing the three screws of the bottom of the compartment portacasco and extracts the same one.

- the Clearing spark plug. cleans to rededor the dirt of the base of the spark plug before to disassemble it.

SPARK PLUG

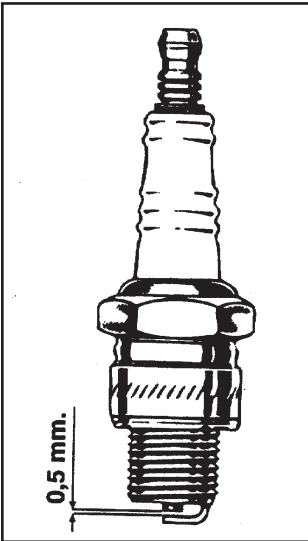

Spark Plug

Marks of spark plug:

NGK B10 ES

Periodically disassembles to spark plug, cleans the electrodes and observes its wearing down. Verify that the separation of the electrodes is of 0.5 mm using a caliber of thicknesses for spark plug.

Spark plug debera to change it each **6.000 Kms.** using the mentioned marks.

PRECAUCION

the inadequate use of one spark plug can lead to severe damage of the motor.

LUBRICATION AND LUBRICATES

Lubrication and lubricates

periodically To verify the oil level of camblo. In order to control to change the oil, it disassembles the right semi-fairing. If the level is low, it extracts the cork of the swim located upon Body right and anada oil of the recommended one.

Each 6.000 km to completely replace the oil of camblo. For it with the hot motor, it extracts the cork of drained oil of the it covers right Body and of central Body, and lets drain all the oil. To return to mount the corks of drained and through orificio of clean-do, to introduce **0.650 liters** of **TRAN-SOIL 10W 30**.

Periodically:

- To lubricate all the transmissions (cables) of the controls, engages the clutch, gas, etc.

- To lubricate the bearings of the direction. To use fat **LC300**

- To lubricate the chain and rpdillo tensile chain, with oil **MOTYL CHAIN**, despuos of it to have washed carefully with petroleum.

- **Each 6.000 km** like maximo to replace the oil of the front bracket: the clearing rolls front and the mudguard, next it disassembles the superior rubber cork of the legs, torni-lbs superior platina cerraje, the screw of clean oil and the screws inferior platina cerraje.

Extract the legs downwards bracket, once disassembled to vacie the oil and efectue several compressions so that vacie all the oil of the interior. To introduce in each leg, **230 cm³** of oil **FORK OIL 5-10**. For the assembly it comes to inverse the of the disassembling.

In ningun case will lie down oil in the canalization nor in the earth. By the problem of the elimination of remainders and by the fact to need tools, camblo of the oil had to be made make in an Official Service DERBI.

ADMISSION BY THE YOU MINE AND REGULATIONS

Admission by the mines

Each 6.000 Kms. to verify the adjustment of you laminate them since they must be well united and fixed to the support valve admission. To review once verified the adjustment of amines the possible wearing down that could exist between you laminate and the Support valve admission. It is not probable that no opening exists since the wearing down is minimo, but is very important to verify this anomalia because it repels in the correct operation of the motor.

Regulation

the After the period of running and periodically he is necessary:

- Reapretar the nuts of the bolts and exhaust pipe.
- To regulate the control of the clutch, If outside necesano, acting on the tension of maneta the so that it is facilmente sins-not controlable game from maneta the. A gap of 2 to 3 mm is recommended.
- Regulation of this game is important correct the.
- To regulate the flow management acting on the tension located in puno of gas and on the located one in the carburetor.

TENSION CHAIN

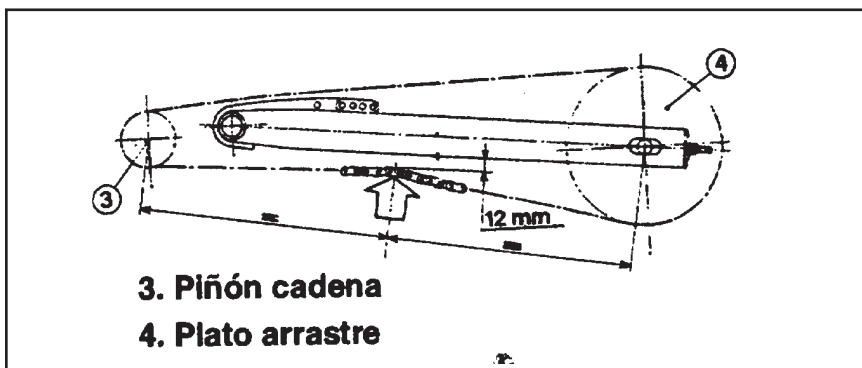
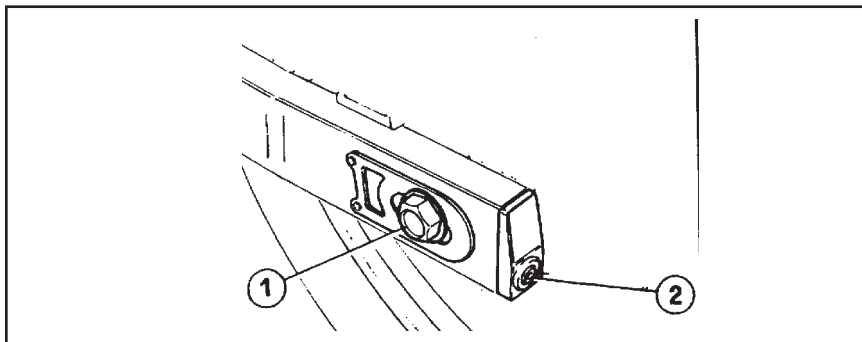

Tension chain

Each 1,500 km is necessary to control the tension of the chain and, if outside of necessary it, to fit it and to lubricate it. The chain is regulated perfectly when, putting the moto vertical and unloaded, is in the demonstrated conditions segun the drawing.

- In case this does not happen, untighten the screw (1)
- Isano to fit it of the following way (2) restores the correct tension;
- It verifies that the notches that encuen- tran in the tension of chain within the balance of the bracket esten aligned to both sides
- un tightens nut of the axis (1) of the un rolls and Pin chain screws (2)'de fits. tensibn of.
- the controls the other side again

CHARACTERISTIC OF THE DISK BRAKE

Charactersticas of the disk brake

the compared disk brakes with those of drum have the following characteristics and advantages:

- the heat evacuation of the supeificies of friction is very effective, since the discs turn in direct bonding with the air. For this reason always we have a capacity of stable braking, even using the brake repeatedly at high speeds. Said of the another way the risk of "Fadding" is far below.
- None of the pieces of the disk brake this exposed to deformation some, by the high temperatures.
- the change of the brake pads is simple and not requere complicated adjustments.
- a constant operation makes sure the brakes, since even being the disc wet, during the marches in time lluvioso, the capacity of recupsraci6n of the braking force is excellent, due to the characteristics of extreme pressure of the brake tablets.
- a smooth tact Has, since solo has a pequena, but sufficient, zone of friction.

MAINTENANCE DISK BRAKES

the eliminate of brake:

Periodically to verify the level of the liquid tank of of brake. To replace it of being to ne-cosar it with the eliminate hidraulico **Brake fluid DOT 4**, never mixes different new and old do liquidos.

With oil deposito abierto not aprieto the handle on surface, do to contrar it podna to dorramar ol the eliminate and ste to dotoriorar the painted superficies and the cristalos. Well-taken care of layer under the do not mix water with oil liquido do throne. Dobido to the absorption do mendable humodad roco-E to change ol once to You liquido to the anus.

Flexible tubes and racordaje:

To verify periodicamonto the floxiblos hi-draulicos tubes, under have not detori-orado and quo ol racordajo nonlayer pordidas.

Tablets of brake:

When ol frono chirrie, puodo sister motivated by the causes:

1. - Funcionamiento incorrect of frono.
2. - Dosgasto do the tablets. These llovan sistema to warn do his dosgasto excosivo, quo haco llogado ol momento to hiss ol frono. In both cases it goes to an OFFICIAL Service DERBI.

Air in the braking system:

If rocorrido do the handle do brake under excosivo haco the handle tiono a soft tact excosivamonto esponjoso, under dobo ro-to stake out a purge do airo dol sistema do brake.

Air purge:

To mount a plastico tube do transparonto on ol purgador to avoid quo liquido residual onsuclo ol sistema do fronado. Aprotar the ma- the notices frono to maximo, to relax the purgador and volverb to aprotar, dojar do to aprotar the manota and frono. Ace sucosivamonto until oliminar ol airo oxistonto in ol sistema do fronado. Roponor a oliminado voice ol airo ol dop6sito do liquido hidraulico **DOT 4**.

Disc of brake:

the superficie of the disc dobo to ostar acoito book do. In order to clean it to utilico alcohol and a smooth rag.

HEAD LIGHT

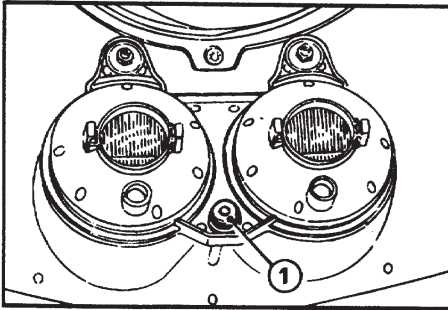
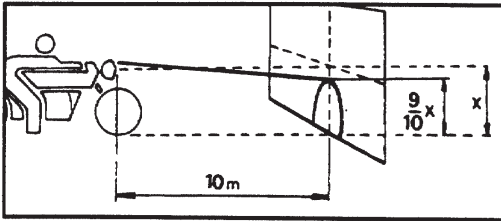

Direction of the light

Gompruebe periodically the orion-tacion do the luz of the light do manora the quo under indicates next:

- 10 meters puts ol do vertical distance do one parod;
- asegu rose do quo the land well is made level and do quo the optical axis of the light is perpendicular to the wall;
- vehfculo under has quo to find vertical On guard;
- height measures the from the center of the light to the ground and marks in the wall a cross the same height;
- to oncondor the luz do cruco, ol lfmito superior do demarcation onto the dark zone and aparocor the illuminated zone tiono quo to the 9/10 a height nonsuperior to do the height from ol ground of contro of the light.

If under tuvieso quo hacer a rectification do the direction, same the under the can efectuar acting in the button (1) quo under oncuntra between the two lucos of the light; memory quo screwing the button the luminous beam under dingo towards above and destomillando the button the luminous beam under dingo downwards.

LAMP LIGHT

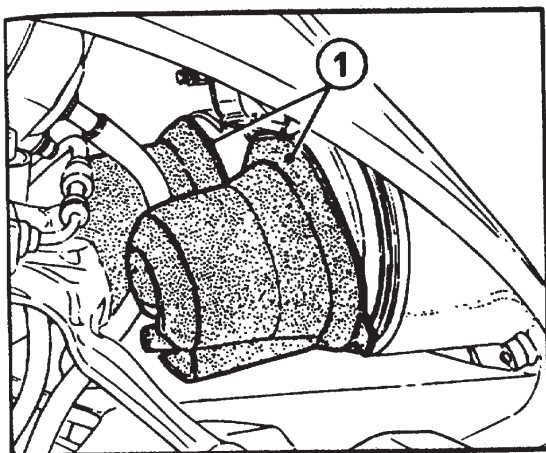

- to change to the lamp of the light, it disassembles the capuchon of rubber (1) of protection of lamp — you stop.
- Clearing porta lamparas towards left and extra the igalo of the optical group.
- to remove to the lampara from portalamparas it inwards does ~ pressure and girela towards left the
- Efectue the substitution and comes from inverse way to return to mount. Jr

PRESSURE OF THE TIRES

Pressure of the tires

a pressure different from the senalada in this section can be reason for defects in the conduction of vehiculo. For that reason controlling turns out very advisable and to correct these pressures frequently.

OBSERVATION:

the correction of the presibn of inflation hara only when the neumaticos esten cold. If they estan Hot, the modification of inflation lhara..solo in the cases in that the pressure is too low. the insufficient air pressure in the neumaticos nonsingle accelerates the wearing down of the neumatico, but that also affects seriously to the stability of the moped. Asegurese of which the pressure of the neumaticos this within the lf-mites esDecificados in the box.

Neumatico Neumatico Pressure of cold Back Forward inflated in
1.8Kg/cm.2 2.0 kg/cm.2

A neumatico with a pressure excessively lowers, unnecessarily increases to the consumption of fuel, repelling it in medlo atmosphere.

PRECAUCION!

Try to always circulate with the neumaticos in good conditions, since If does excessively with neumaticos worn away reducira the stability of conduccibn and can llevar to him to a lost one of control. It is recommended that the front neumatico changes when the depth of estrfas is of 1, either mm 0 the less. In order to avoid the wearing down to unnecessary of the neumaticos it is recommended:

- To always take to the neumaticos with the suitable pressure of inflation.
- To lead smoothly avoiding the sudden accelerations and brakings.
- To try of not clearing the curbs of the sidewalks with the wheels.

CONTROL THE ELIMINATE COOLANT

Control the eliminate retriigerante

Each **1,500km** after long trips is due to control with the motor in cold, the level of the eliminate of refrigeration, that must less locate in the half of the expansion tank.

In case of contrar it, it completes the tank. In order to change the cooling liquido one, to remove the cork from the expansion tank and to disassemble the screw of drained of the water pump, draining this way all the eliminate.

After mounting the drained thyme again of, to fill up all the circuit with **50 cooling liquido INUGEL and 50 mineralized water**, through the orifice of the tank of expansion, having the precaution of which the tank less the has left but half of its capacity. An excess of liquido provocarfa that left by the cork during the use vehicle.

OBSERVATION:

- To verify the state of the sleeves. —
- If during the normal use of the moped the temperature indicator ignites to him, to stop the motor and to hope to that infrie the eliminate coolant, next with the cold motor to verify the level of the cooling liquido and to possibly fill up. It never extracts the cork of the tank of expansion with the temperature of the eliminate hot coolant.
- the filled up one of the cooling liquido one is necessary to carry out it with the motor.

BATERIA AND FUSE

Instructions of assembly of the batterie

- the Unblocks lock placed ahead of storage of the pilot and raises the covers compartment portacasco.
- Clearing the three screws of the bottom of the compartment portacasco and extracts the same one.
- battery in its lodging Places the and connects the RED cable to (+) and the BLACK (-).

Maintenance to battery

it the good maintenance of the battery must include:

- To always maintain the level of the water between the lñneas superior and inferior of the divides frontal of the container. Of being to necesar to replace it with distilled water. To avoid the overloads.
- To maintain the corks of the perfectly closed glasses. It is important.
- To maintain the starts off superior completely cleans, dry and free of corrosive matters, the tips of the baterfa must be clean and lubrications, to avoid the corrosion.
- To verify the residual capacity of You go baterfa with densfmetro. A superior density of **1,265** or is good, of being inferior carguese the baterfa. the recommended current of load is of **0.5 + 1 To maximo**, until recommended density is obtained to the.
- battery when unloading between a 0.5% is not used approximately and a 1% diano. This average increases with the temperature. In order to compensate a recovery load must be done once to the month.

BATERIA AND FUSE

- One battery contains acid sulfuric. Avoid the contact with the skin, eyes and clothes.

PRECAUCI6N!

When recharging intensity of maximum 0.5 + 1 will not have to be exceeded the Amperes hour, because destroying the battery.

Change of the battery

if there were to change battery then, be careful that to make it by another one of equal capacity and **12V. 4Ah.**

Because of the old problem that represents the remainder of battery, better it is to make replace the battery by any Official Service DERBI. Battery contains among other substances, acid sulfuric and in any case must not be thrown to the domestic sweepings.

Fuse

In the case of having to change the fuse of the electric system by to have fused, to make sure whenever it is of same amperage it is of **4 Amp.**

the fuse is within the housing of the battery; for its substitution, to clear it of the support and to change it for a new one.

PRECAUCI6N!

It never uses a fuse that is not of 4 Amp. since it can damage the electrical system. In the case that this happens to him in a short period of time, he should consult an Official Service DERBI.

PICTURE DO MAINTENANCE AND LUBRICATES

- (A) Greasy LC 300
- (B) 10 Oil TRANSOIL W 30
- (C) Oil MOTYL CHAIN
- (D) Acate Forkolls- 10
- (E) The eliminate INUGEL 50

	break in	1.000 Kms.	3.000 Km.	6.000 Km.	10.000 Km.	TO USE
Presión de los neumáticos	■					
Fuel in the deposit	■					
Carburante en el depósito	■					
Eficacia del embrague	■		▲			
Eficacia de las suspensiones	■					
Brakes	■					
Frenos	■	▲		■		
Cadena de transmisión secundaria	■	▲		■		■
Transmisiones de los mandos (cables)	■	●			◆	C
Acetite del cambio	■	◆			◆	A
Apriete culata		■		■		B
Apriete tornillería		■			■	tighten 1,9 m. Kg- boque 0,6 m. Kg.
Líquido de freno	■		■		■	
Limpieza conductos alimentación				■	◆	
Líquido refrigerante		■		■	◆	
Eje basculante y ejes ruedas		■				E
Bujía		▲				
Filtro aire			▲		◆	
Rodamientos dirección			▲		▲	
Juego segmentos - cilindro				■	■	A
Limpieza culata, piston y lumbreras				▲	◆	
Carburador			▲		▲	
Horquilla delantera				◆	▲	
Admisión (láminas)				◆	◆	Gasoline and air D

Check Regular / Clean Oil lub Change

NOTE: All these instructions are orientativas and dependers in great 51 pair to him of uses dsdo moped, Highway or lode terreno hectic of which the picture indicatas qua on the 1,500 secanismo must the am verified p. if to kas quise not to say qua to under luncionamiento ace salislaciono dabs ' esllizanci this tevisine.

CLEANING

Cleaning

the general maintenance of its moped is simple. If besides to fulfill the instructions given in this book, they clean his moped periodically, the yield will be to davfa superior.

- For the enameled painted surfaces and of plastic IT NEVER USES gasoline, petroleum etc. fr6telas with sponge and sequelas with chamois. It can, once dry, to pass some paste polisher of the employees in carrocerfas wax of the automobiles, carrying out it with wool rag.

- Case that it is surprised by the lluvia, is recommendable to clean and to dry vehicub immediately and to lubricate all cables.

When buying conservation products habrfa that to choose those that are ecological. the remainders of such you would not deberan to lie down to the sweepings domestic servant.

In interest of the medio.ambiente, the moped had to wash only eji the places specially anticipated for it. To wash vehfculo outside these in certain zones.

CONSERVATION IN LONG PERIODS DO INACTIVITY

Conservation of the moped in perfodos lengths of inactivity

- general Cleaning and drying.
- To drain the cooling liquido oil, gas tanks.
- To drain the oil of the motor. Not to place the drained cork of, in its place to cover with a clean rag.
- To remove to the spark plug. By its lodging introdu
- the 10 + 15 cc. of anti-corrosive oil to to turn the motor so that it is left all grease and pregnado one and prote'ge'.
- To lubricate all the metalicas parts with anti-rust fat oil; at the moment they exist in the market sprays very adapted for this type of protection. (WD40)
- To protect the moped with a plastico, to avoid the dust accumulation.
- He is advisable that the wheel do not touch to the ground.

POSSIBLE LOCATION OF TROUBLESHOOT

In this CAP ftulo descdbbe the way to locate and to repair to pequenas anomalfas.

Index of capftulo	page
Abnomal ace in route	50

ABNORMAL IN ROUTE (TROUBLESHOOT)

Anomalla in route.

It is not probable that a bike in route appears If the moped well is conserved and it has been dealt with the taken care of had one.

If, however, it can appear in a while given, that vehculo stops abruptly and there is no form to put it in run.

In this case, the conductor who does not have ample knowledge of mecanical, only must verify two points, that are generally those that causes the halting without for that reason vehiclo is damaged.

Verify If low gasoline from of-the posito to the carburetor. Once verified which the gasoline descends, only lack to verify If the ma-Peruvian bark has good spark, is to say If to traverse of the cable of high tension, that goes Connected to the spark plug, Ilega current the electrica necessary to produce tipsy the between the electrodes of the spark plug.

In order to carry out this verification, it disassembles to the spark plug, using the llave that stops such aim is given with the equipment of tools of the moped.

Once disassembled to the spark plug it observes If it presents/displays the “to per it”, that is not another thing that some particular of fine coal deposited between the electrodes of the spark plug.

Of being, a sheet of paper uses a knife to eliminate it. Mount again the spark plug so that the moped starts up.

If by the contrano when disassembling the spark plug the notices lubricated, that is to say, with an oil layer that covers the electrodes, the replaces spark plug by another one (that debera clean always of spare part, in the hagala and toolbox) to take the grease out of in a factory.

SPECIFICATION

In the following pages of this CAP to the engineering specifications and Index are described.

Index de capítu	page
Technical Characteristics	52 - 53 - 54
Index	56

CHARACTERISTICS TEONICAS

MOTOR

the number of cylinders

a cylinder of aluminium with inner covering of nickel and silicon carbides.

Cycle

2- stroke.

Bore and stroke

39.88 x 40mm

Rolled c.c.

49.94 c.c.

Compression ratio...

11,5:1

Direction of rotation

Izquierdo flying side magnotico

Refrigeracion of the motor

By the eliminate coolant - water coolant

Carburatane

Super Gasoline

System of lubrication

Mixture of gasoline and oil with lubricacion by means of pump. Injection oil

CARBURETOR

DelÍOrto PHVA - 17.5 with starter manual

CLUTCH TYPE

oil multiple barium discs. - wet clutch

Primary transmission By rectified gears

THE ADMISSION

By you laminate direct Body

TECNICAS CHARACTERISTICS

GEAR OF SPEEDS

the number of speeds Six

Selector

Selector with bracket and distributing drum driven by outer selector

Relations

I Gear	11/34 Speed
II Gear	15/30 Speed
III Gear	18/27 Speed
IV Gear	20/24 Speed
V Gear	22/23 Speed
VI Gear	23/22 Speed

SECONDARY TRANSMISSION

Type

By chain, of step 12.70 mm and diametro of roller 7.75 mm

Relation 14/52

STARTING

Type. Electrico

ignition. C.D.I.

ELECTRIC

Ignition Electronic System 12V. 70W.

AvancealPMS 1.2 mm.

Spark NGK B10 ES

Baterie 12 V.4 Amp.

TECNICAS CHARACTERISTICS

ILLUMINATED

Nose light	12V. 25/25 W.
Faro back pilot-light piloto/stop	12V. 21/5 W.
Intermitentes	12V. 10W.

CHASSIS

Chassis

Type of two beams of tubes of prismatic steel section of high resistance.

Front suspension

SHOWA hydraulic inverted Bracket of centered axis.

Tilted back suspension

GAS monoshock progressive link with a hydraulic shock absorber adjustable power station

Brakes rolls front

hydraulic disc 260mm of great effectiveness.

Brakes rolls back

hydraulic disc 218 mm of great effectiveness.

Front Tire

90/90 x 16" MT 75

Back Tire

120/80 x 16" MT 75

TECNICAS CHARACTERISTICS

DIMENSIONES

Length overall	1,900 mm.
Wheelbase	1,315 mm.
Width (in the handlebars)	600 mm.
Maximum height	1,135 mm.
Height of the lowest point to the ground	125 mm.
Height sill in	770 mm.

BENEFITS

Maximum Power

8.00 CV. to 8,750 r.p.m.

Speed maximum and maintained

45 Km/h. (the regulated by the law for a moped)

Redline of turn of motor

11,500 r.p.m.

Tank gas

2 gal.

INDEX

Personal Data	4	Separated Lubrication	28
Controls	5	Air Filtro	29-31
Identifications or Liaves	7	Carburetor	32
Indications	7	Spark plug	33-34
Instruments and controls	8-9	Lubrication and lubricates	35
Tablier	10	Admission by you laminate	36
Interrupter lights and pulser	11	Regulations	36
Control intermittent lights,	12	Tension chain	38
horn and Control	13	Characterfsticas of the disc brake	38
front brake	13	Maintenance disc brakes	39
Control Lock of contact	14	Nose light	40
Control embrague	15	lights	41
Control starter	15	Pressure light	42
Control back brake	16	Cooling	43
Handle change	17	Bateria	44 - 45
Grifode gasoline	18	Fuse	45
Equipment and accessories	19	Table maintenance	46
Tank gasoline	20	Cleaning	47
Oil tank	21	Conservation of the moped in long periods of	48
cooling liquid Tank	21	Storage inactivity	49
Starting, conduction	22	Troubleshoot in route	50
Instructions beginning	23	Tecnical	51
Conduction	24	Specifications Caracterfsticas	52 - 53 - 54
Running	25		
Advice	26		
Maintenance	27		